

MAC Panel Company

SCOUT Instructions DAK Insertion and Removal

Contents

| | |
|---|----|
| Mounting and Extracting DAKs from a SCOUT system - Overview | 2 |
| Step 1 Inserting and extracting a single wide DAK..... | 3 |
| Step 2 Identify the 2 styles of Screw..... | 5 |
| Step 3 Inserting the DAK | 6 |
| Step 4 Removing the DAK | 8 |
| Appendix A DAKs with 2 slots or more | 10 |
| Appendix B Possible Damage to Receiver..... | 11 |
| Appendix C DAK Tool Kit Contents | 12 |

Figures

| | |
|---|----|
| Figure 1 SCOUT Tool Kit | 2 |
| Figure 2 DAK in position to be inserted into receiver..... | 3 |
| Figure 3 Align the PXI card in the correct chassis slot..... | 3 |
| Figure 4 Push the assembly into the chassis..... | 4 |
| Figure 5 Jacking Screw | 5 |
| Figure 6 Locking Screw | 5 |
| Figure 7 DO NOT use the top screw first..... | 6 |
| Figure 8 Insert the DAK using the jacking screw | 6 |
| Figure 9 Lock the DAK in place | 7 |
| Figure 10 Undo the locking screw first | 8 |
| Figure 11 Extract the DAK from the chassis backplane using the jack screw | 8 |
| Figure 12 Fully extract the DAK..... | 9 |
| Figure 13 Example of a double wide DAK | 10 |
| Figure 14 Jack Screw | 11 |
| Figure 15 Damaged helicoil in receiver | 11 |
| Figure 16 DAK Tool Kit..... | 12 |

Mounting and Extracting DAKs from a SCOUT system - Overview

The diagrams and instructions apply to all MAC Panel DAKs and SCOUT receivers.

Warning

It is important to follow these instructions for both insertion and extraction as damage to the receiver and/or DAK can occur if installed or extracted incorrectly.

To complete this assembly process, you will require the following:

- MAC Panel DAK correctly attached to the appropriate PXI or PXIe instrument.
 - Full instructions for this are available at www.macpanel.com
- SCOUT receiver mounted on appropriate chassis.
- DAK tool kit, MAC Panel part number 561211 <https://www.macpanel.com/product/561211/>
 - The tool kit contains all tools to ensure satisfactory assembly.



Figure 1 SCOUT Tool Kit

The images in these instructions are taken from an assembly video that can be found at:

<https://youtu.be/U2hbsjzKis>

Step 1 Inserting and extracting a single wide DAK.

To perform this operation, you will require the following tools from the DAK tool kit:

- 3/16" slotted screwdriver
- DAK removal tool, part number 5212346



Figure 2 DAK in position to be inserted into receiver.

Align the assembled DAK and PXI instrument with the required chassis slot position. It is critical that the PXI PCB is correctly located in both the upper and lower card guides.

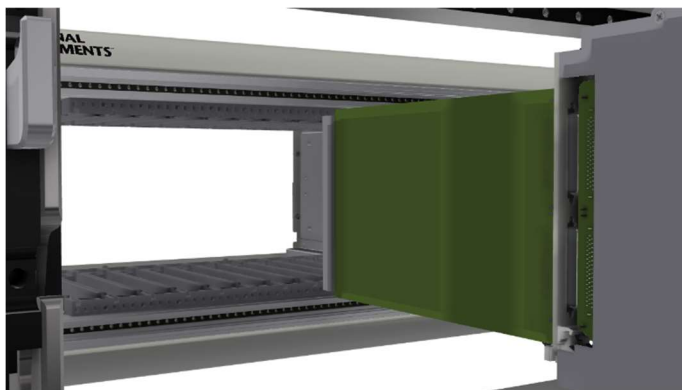

Figure 3 Align the PXI card in the correct chassis slot.

Slowly push the assembly into the chassis until you feel slight resistance, at this point the rear connector on the PXI card will be ready to be inserted into the chassis backplane connector.

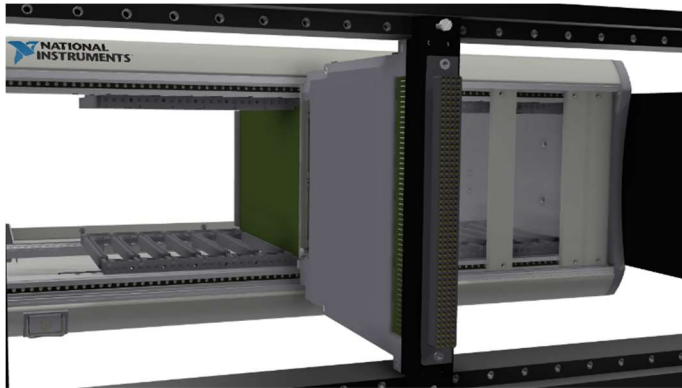

Figure 4 Push the assembly into the chassis.

Step 2 Identify the 2 styles of Screw.

There are 2 styles of screw in a DAK.

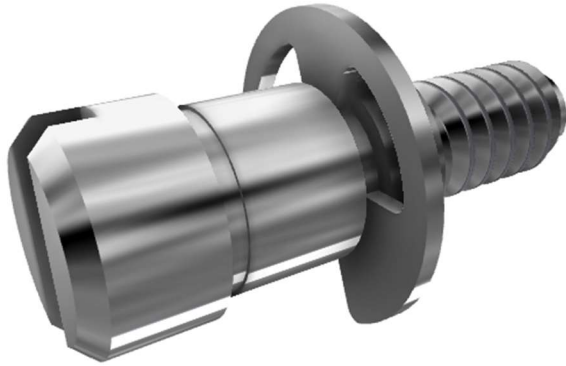

Figure 5 Jacking Screw

The jacking screw is located at the bottom of a DAK and is used to insert and extract the DAK.

When INSERTING: **Activate FIRST**

When EXTRACTING: **Activate LAST**



Figure 6 Locking Screw

The locking screw is located at the top of the DAK and is used to fasten the DAK into place, after it has been inserted with the jacking screw.

Step 3 Inserting the DAK

It is critical that the screws are actuated in the correct order. In a single wide DAK, the top screw is used for securing the DAK. The bottom screw is a jackscrew and is used to screw the assembly onto the chassis backplane.

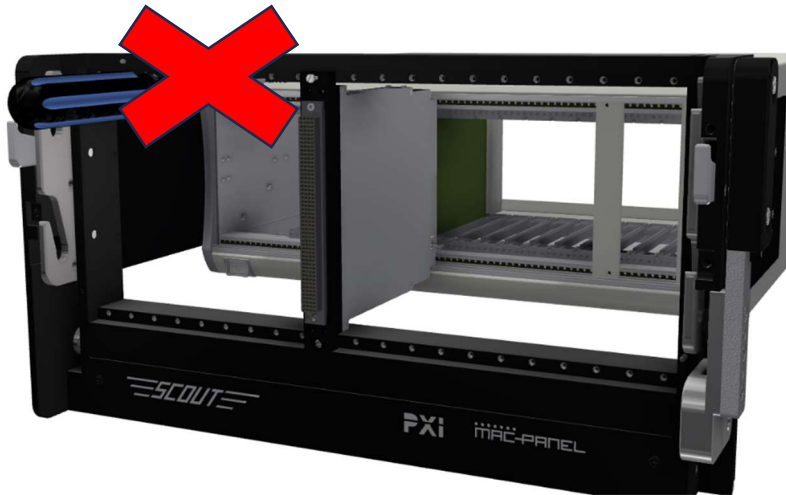

Figure 7 DO NOT use the top screw first.

Screw the DAK into the assembly using the jack screw.

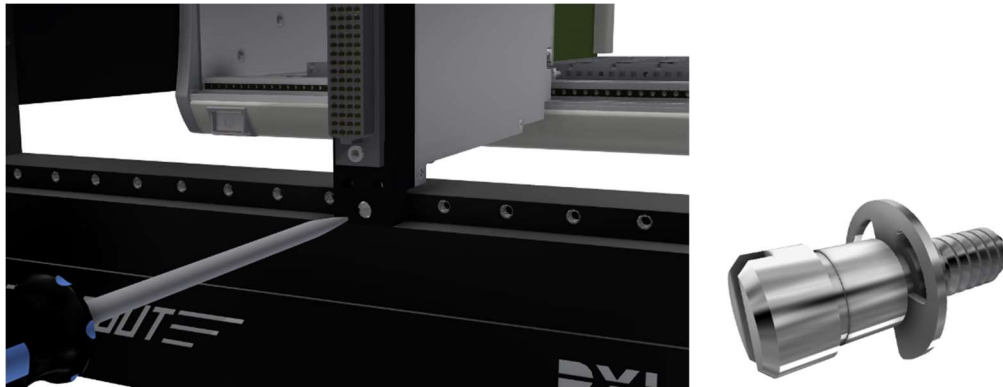

Figure 8 Insert the DAK using the jacking screw.

Tighten the DAK into place using the locking screw.

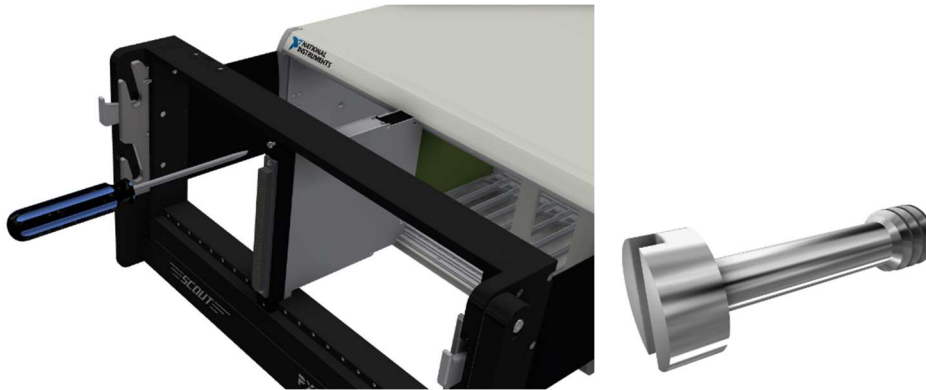

Figure 9 Lock the DAK in place.

Step 4 Removing the DAK

Again, it is critical that the screws are actuated in the correct order.

DAK removal is the opposite of insertion.

Screw the DAK into the assembly using the jack screw.

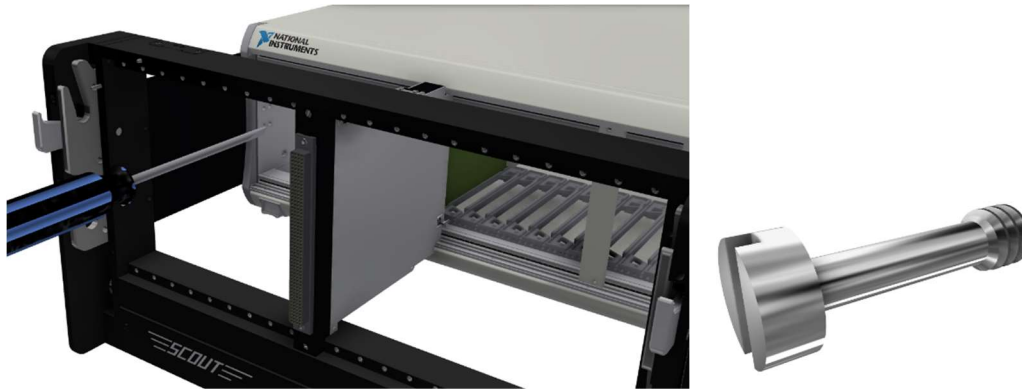

Figure 10 Undo the locking screw first.

Extract the DAK and PXI instrument from the backplane by unscrewing the jack screw.

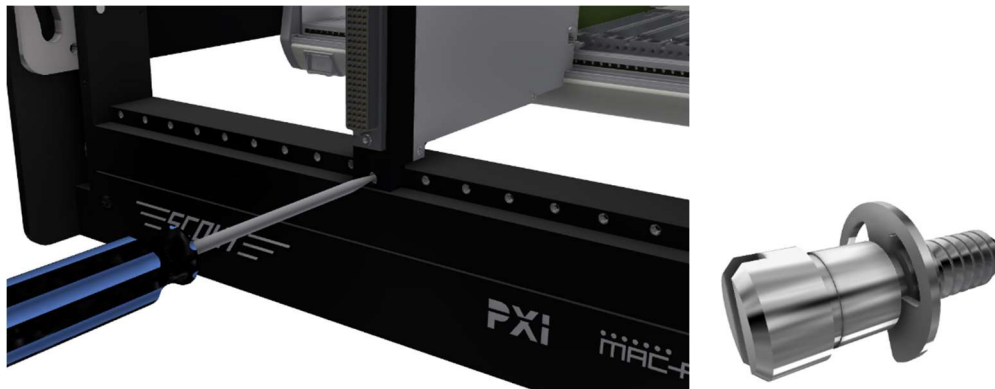

Figure 11 Extract the DAK from the chassis backplane using the jack screw.

Remove the DAK completely with the aid of the removal tool, part number 55123465.

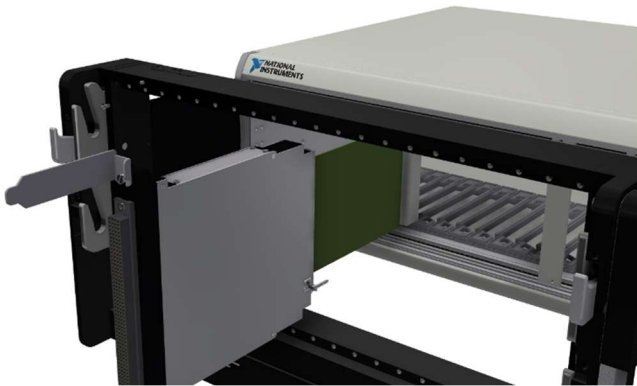

Figure 12 Fully extract the DAK.

Appendix A DAKs with 2 slots or more





Some DAKs are wider than a single slot.

In all instances it is critical that the jack screw is activated first when inserting the DAK and last when extracting the DAK. This is shown in more detail in the video.



Figure 13 Example of a double wide DAK

In the example above, there are 4 screws, 1 jack screw and 3 locking screws, located as shown:

| | |
|--|--|
| <p>Top Left</p>  <p>Locking Screw</p> | <p>Top Right</p>  <p>Locking Screw</p> |
| <p>Bottom Left</p>  <p>Jack Screw</p> | <p>Bottom Right</p>  <p>Locking Screw</p> |

Appendix B Possible Damage to Receiver

Warning

It is critical that the following rule is always applied:

When INSERTING: Activate FIRST

When EXTRACTING: Activate LAST

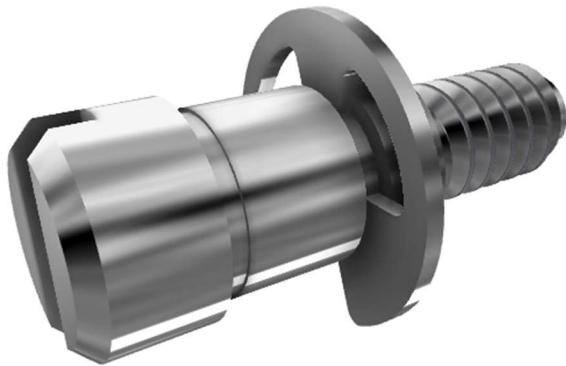

Figure 14 Jack Screw

If this rule is not followed it is highly likely that the receiver will be damaged. Each threaded hole in the receiver has a helicoil fitted to improve the strength of the thread. In normal use this thread will last the lifetime of the receiver, but incorrect DAK insertion or extraction can result in the helicoil being damaged as shown below.

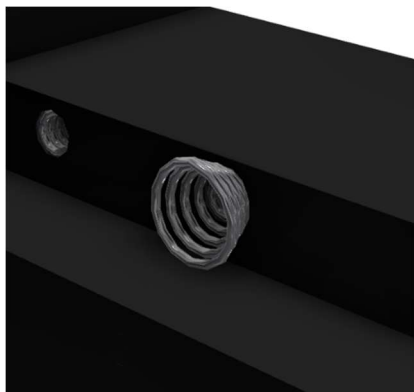

Figure 15 Damaged helicoil in receiver

Appendix C DAK Tool Kit Contents

The DAK Tool Kit, part number 561211, includes all necessary tools to assist with satisfactory DAK assembly, insertion and extraction



| | | | |
|---|---|---|---|
| A | B | | |
| C | D | E | F |
| G | | H | |
| J | K | | L |

Figure 16 DAK Tool Kit

| Location | Description | Part # |
|----------|---|-------------------------------------|
| A | Alignment Tool | 412640 |
| B | Assorted Screwdrivers | #1 Philips #2 Philips 3/16" Slotted |
| C | Nut Extraction Tool | 561588 |
| D | Spare T bolts and nuts | 5510941 4-40UNC |
| E | Patch cords for probing female contacts | PC 000 150 024 012 |
| F | DAK Removal Tool | 5212346 |
| G | Combination Wrenches | 3/16" 1/4" |
| H | Nut Driver | 1/4" |
| J | Ejector Pin Extraction Tool | 5515529 |
| K | Hex Keys | |
| L | Spare Screws and nuts | |