

- NOTES:
1. CHECK PIN-OUT TO 5517888 DRAWING
 2. BAG AND 5510991 (1X), 5510941 (1X), 440E9230 (1X).

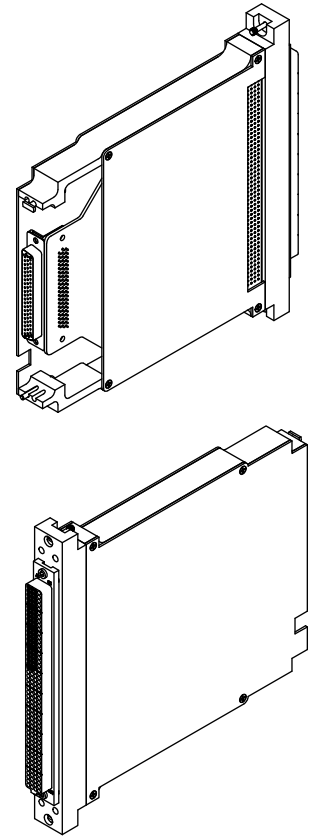
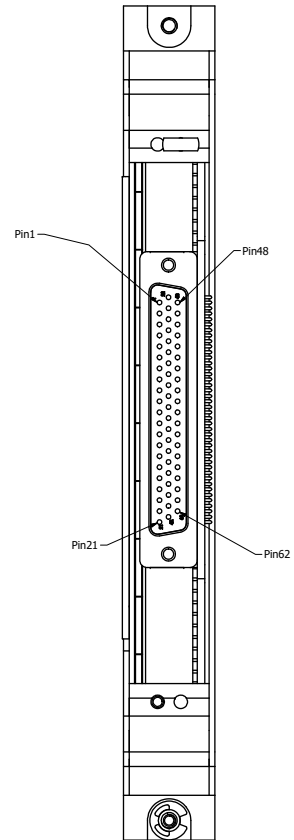
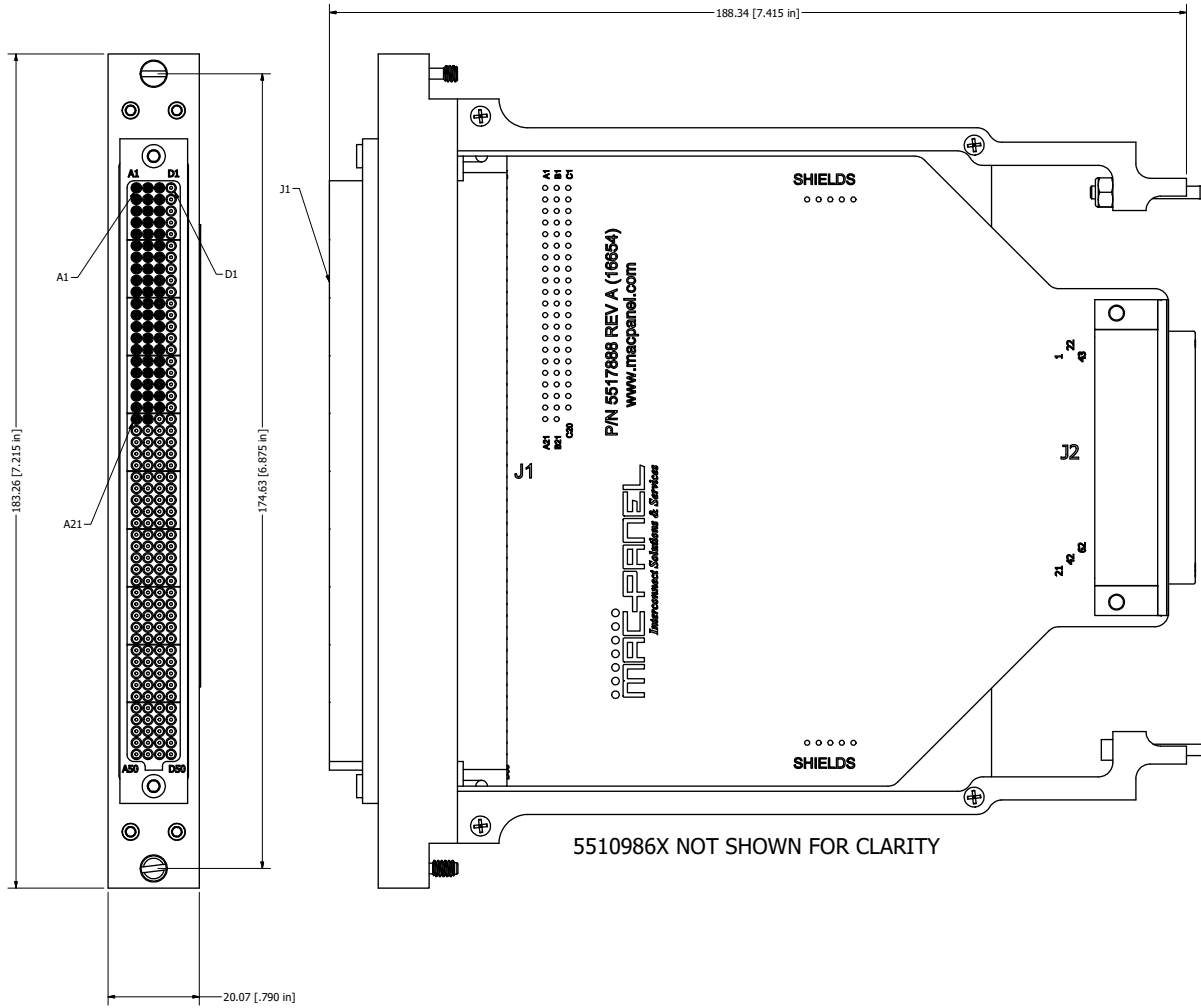

BALLOON LEGEND	
PART NUMBER	QTY

MAC PANEL PROPRIETARY
This document may contain confidential and proprietary information that is the property of MAC Panel Company that may not be disclosed to, or duplicated for others except as authorized by MAC Panel Company.

TOLERANCES (UNLESS OTHERWISE SPECIFIED)

SHEET METAL	FINISHES:	Third Angle Projection
ANGLES ± 1°	ANGLES ± 1°	
XX ± .03	XX ± .01	
.XXX ± .010	.XXX ± .005	
	.XXX ± .005	

REMOVE ALL BURRS AND BREAK SHARP EDGES.

DRAWN BY HN ENGINEERING	24/07/2018	MAC PANEL COMPANY - HIGH POINT, NC	
SALVATINI OPERATIONS	24/07/2018		
TITLE		DAK,PCB,Ext,62 Pin D-Sub,Female	
MANUFACTURING L'LEVAN ASSEMBLY	30/07/2018		
MATERIAL USED			
SIZE D	CAGE CODE 16654	DWG NO 562822X1-CU	REV A
SCALE	SPN: 562812X1	SHEET 1 OF 2	

NOTES:

- CHECK PIN-OUT TO 5517888 DRAWING
- BAG AND 5510991 (1X), 5510941 (1X), 440E9230 (1X).

PIN-OUT	
J1	J2
A1	1
A2	2
A3	3
A4	4
A5	5
A6	6
A7	7
A8	8
A9	9
A10	10
A11	11
A12	12
A13	13
A14	14
A15	15
A16	16
A17	17
A18	18
A19	19
A20	20
A21	21
B1	22
B2	23
B3	24
B4	25
B5	26
B6	27
B7	28
B8	29
B9	30
B10	31
B11	32
B12	33
B13	34
B14	35
B15	36
B16	37
B17	38
B18	39
B19	40
B20	41
B21	42
C1	43
C2	44
C3	45
C4	46
C5	47
C6	48
C7	49
C8	50
C9	51
C10	52
C11	53
C12	54
C13	55
C14	56
C15	57
C16	58
C17	59
C18	60
C19	61
C20	62

BALLOON LEGEND

PART NUMBER
QTY

MAC PANEL PROPRIETARY
 This document may contain confidential and proprietary information that is the property of MAC Panel Company that may not be disclosed to, or duplicated for others except as authorized by MAC Panel Company.

TOLERANCES (UNLESS OTHERWISE SPECIFIED)

SHEET METAL	DIMENSIONS
ANGLES ± 1°	ANGLES ± 1°
XX ± .03	XX ± .01
.XXX ± .010	.XXX ± .005
	.XXX ± .005

REMOVE ALL BURRS AND BREAK SHARP EDGES.



DRAWN BY HN ENGINEERING	24/07/2018	MAC PANEL COMPANY - HIGH POINT, NC
SALVATINI OPERATIONS	24/07/2018	
MANUFACTURING L LEVIAN ASSEMBLY	30/07/2018	TITLE DAK,PCB,Ext,62 Pin D-Sub,Female
MATERIAL USED		SIZE D
		CAGE CODE 16654
		DWG NO 562822X1-CU
		REV A
		SCALE SPR: 562812X1
		SHEET 2 OF 2