

- NOTES:
 1. CHECK PIN-OUT TO 5517819 DRAWING
 2. BAG AND 5510991 (1X), 5510941 (1X), 440E9230 (1X).

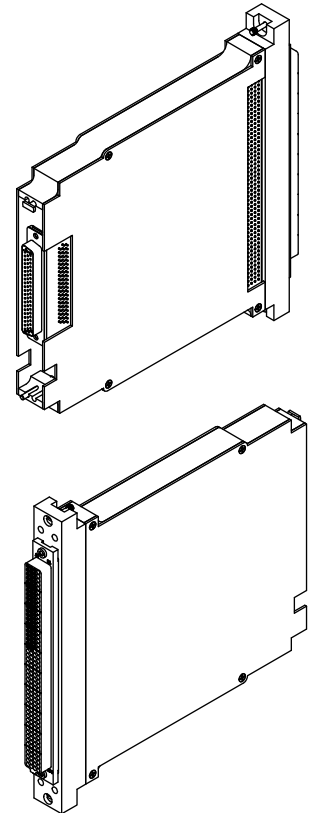
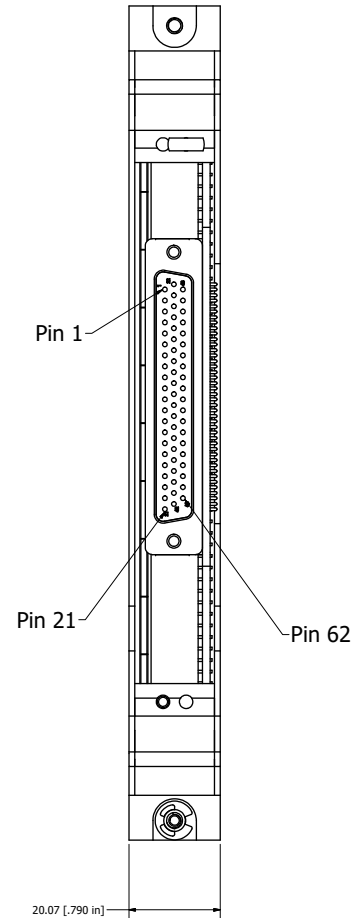
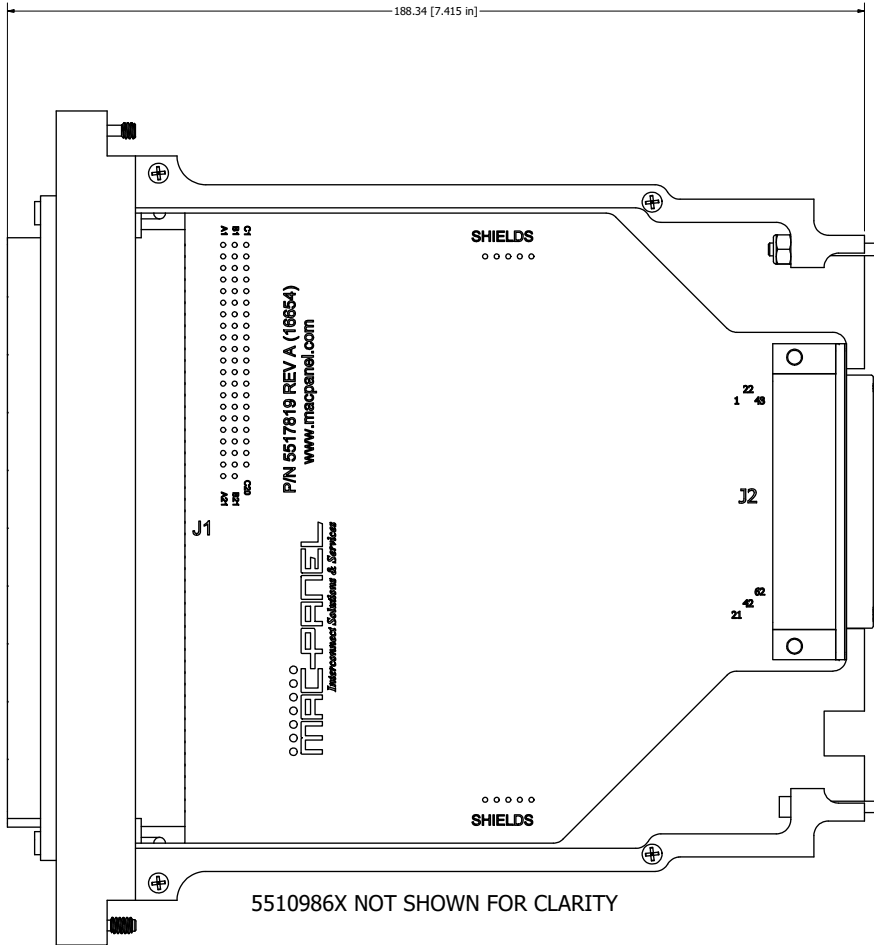
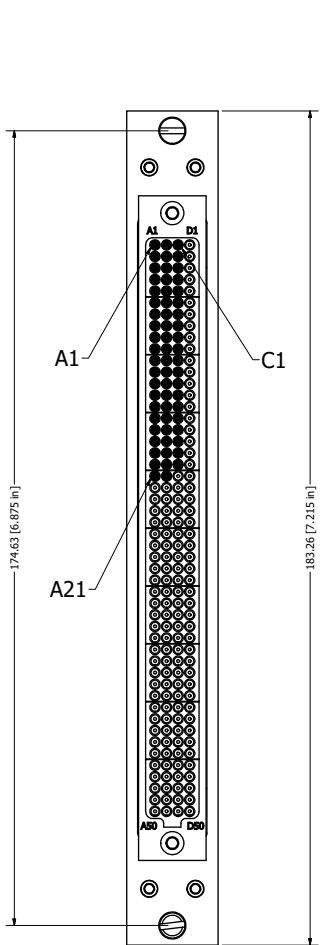

BALLOON LEGEND	
PART NUMBER	QTY

MAC PANEL PROPRIETARY
 This document may contain confidential and proprietary information that is the property of MAC Panel Company that may not be disclosed to, or duplicated for others except as authorized by MAC Panel Company.

TOLERANCES (UNLESS OTHERWISE SPECIFIED)
 SHEET METAL: UNFINISHED: Third Angle Projection
 ANGLES: ± 1° ANGLES: ± 1°
 .XX ± .03 .XX ± .01
 .XXX ± .010 .XXX ± .005
 .XXX ± .005

REMOVE ALL BURRS AND BREAK SHARP EDGES.

DRAWN BY DBC	02/07/2018	MAC PANEL COMPANY - HIGH POINT, NC	
ENGINEERING		TITLE	
OPERATIONS		DAK,PCB,Ext,62 Pin D-Sub,Female	
MANUFACTURING		SIZE	CAGE CODE DWG NO
ASSEMBLY		D	16654 562812X1-CU
MATERIAL USED		REV	A
SCALE	SPR:	SHEET 1 OF 2	

NOTES:

- CHECK PIN-OUT TO 5517819 DRAWING
- BAG AND 5510991 (1X), 5510941 (1X), 440E9230 (1X).

PIN-OUT	
J1	J2
A1	1
A2	2
A3	3
A4	4
A5	5
A6	6
A7	7
A8	8
A9	9
A10	10
A11	11
A12	12
A13	13
A14	14
A15	15
A16	16
A17	17
A18	18
A19	19
A20	20
A21	21
B1	22
B2	23
B3	24
B4	25
B5	26
B6	27
B7	28
B8	29
B9	30
B10	31
B11	32
B12	33
B13	34
B14	35
B15	36
B16	37
B17	38
B18	39
B19	40
B20	41
B21	42
C1	43
C2	44
C3	45
C4	46
C5	47
C6	48
C7	49
C8	50
C9	51
C10	52
C11	53
C12	54
C13	55
C14	56
C15	57
C16	58
C17	59
C18	60
C19	61
C20	62

BALLOON LEGEND
 PART NUMBER
 QTY

MAC PANEL PROPRIETARY
 This document may contain confidential and proprietary information that is the property of MAC Panel Company that may not be disclosed to, or duplicated for others except as authorized by MAC Panel Company.

TOOLERANCES (UNLESS OTHERWISE SPECIFIED)
 SHEET METAL: UNFINISHED:
 ANGLES ± 1° ANGLES ± 1°
 XX ± .03 XX ± .01
 .XXX ± .010 .XXX ± .005
 .XXX ± .005

REMOVE ALL BURRS AND BREAK SHARP EDGES.



DRAWN BY DBC	02/07/2018	MAC PANEL COMPANY - HIGH POINT, NC	
ENGINEERING		TITLE	
OPERATIONS		DAK,PCB,Ext,62 Pin D-Sub,Female	
MANUFACTURING		SIZE	CAGE CODE DWG NO
ASSEMBLY		D	16654 562812X1-CU
MATERIAL USED		SCALE	SPR: 1
			SHEET 2 OF 2

REV
A