

NOTES:

1. BAG AND TAG P/N M25C#5 (4X) PRIOR TO SHIPPING.

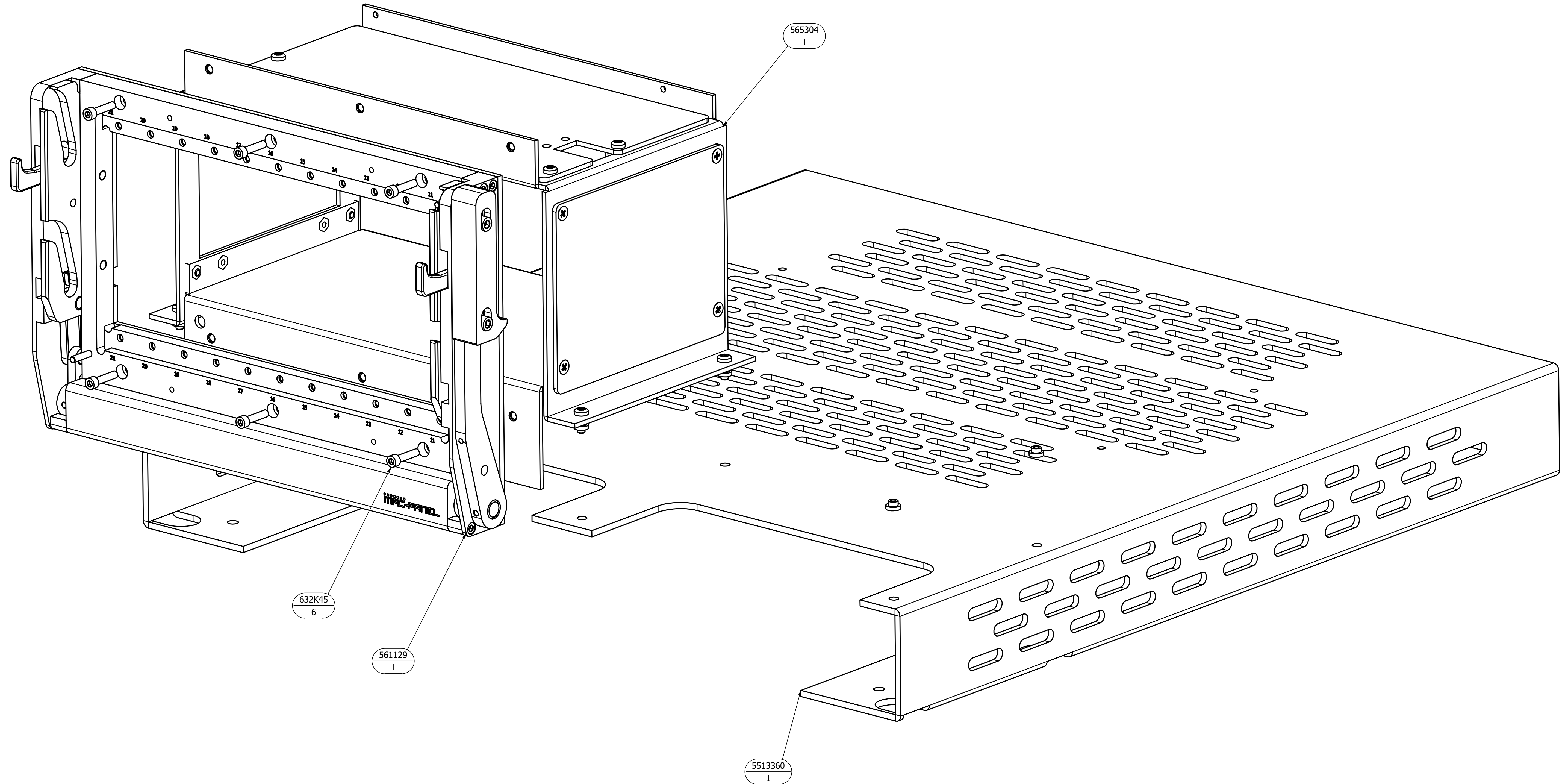

BALLOON LEGEND	
PART NUMBER	QTY

MAC PANEL PROPRIETARY
 This document may contain confidential and proprietary information that is the property of MAC Panel Company that may not be disclosed to, or duplicated for others except as authorized by MAC Panel Company.

TOLERANCES (UNLESS OTHERWISE SPECIFIED)
 SHEET METAL MACHINED
 ANGLES ± 1° ANGLES ± 1°
 .XX ± .03 .XX ± .01
 .XXX ± .010 .XXX ± .005
 .XXXX ± .0005 .XXXX ± .0005

REMOVE ALL BURRS AND BREAK SHARP EDGES.

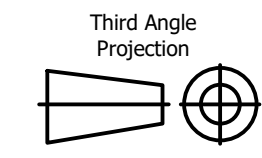

DRAWN BY STE	24/01/2017	MAC PANEL COMPANY - HIGH POINT, NC	
ENGINEERING		TITLE	
OPERATIONS		11 slot SCOUT Express with sheetmetal frame	
MANUFACTURING		SIZE	CAGE CODE DWG NO
ASSEMBLY		D	16654 561120-CU
MATERIAL USED		SCALE	SPN:
AS SHOWN			SHEET 1 OF 3
		REV	B

NOTES:

1. BAG AND TAG P/N M25C#5 (4X) PRIOR TO SHIPPING.

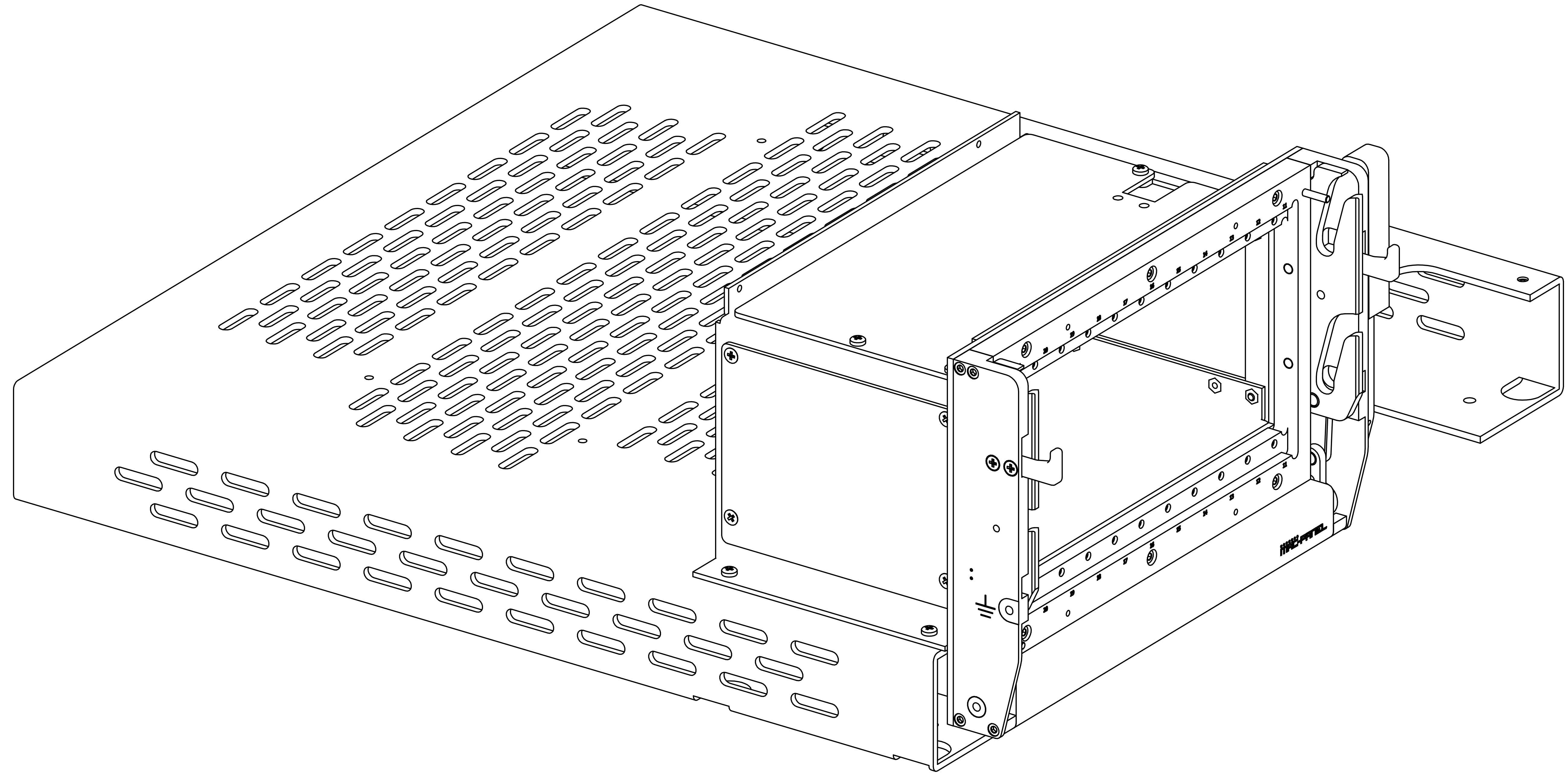

BALLOON LEGEND

PART NUMBER	QTY

MAC PANEL PROPRIETARY
This document may contain confidential and proprietary information that is the property of MAC Panel Company that may not be disclosed to, or duplicated for others except as authorized by MAC Panel Company.

TOLERANCES (UNLESS OTHERWISE SPECIFIED)

SHEET METAL	MACHINED
ANGLES ± 1°	ANGLES ± 1°
.XX ± .03	.XX ± .01
.XXX ± .010	.XXX ± .005
	.XXXX ± .0005

REMOVE ALL BURRS AND BREAK SHARP EDGES.

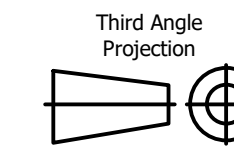

DRAWN BY	STE	24/01/2017
ENGINEERING		
OPERATIONS		
MANUFACTURING		
ASSEMBLY		
MATERIAL USED	AS SHOWN	

MAC PANEL COMPANY - HIGH POINT, NC		
TITLE		
11 slot SCOUT Express with sheetmetal frame		
SIZE	CAGE CODE	DWG NO
D	16654	561120-CU
SCALE	SPN:	SHEET 2 OF 3
		1

REV B

NOTES:

1. BAG AND TAG P/N M25C#5 (4X) PRIOR TO SHIPPING.

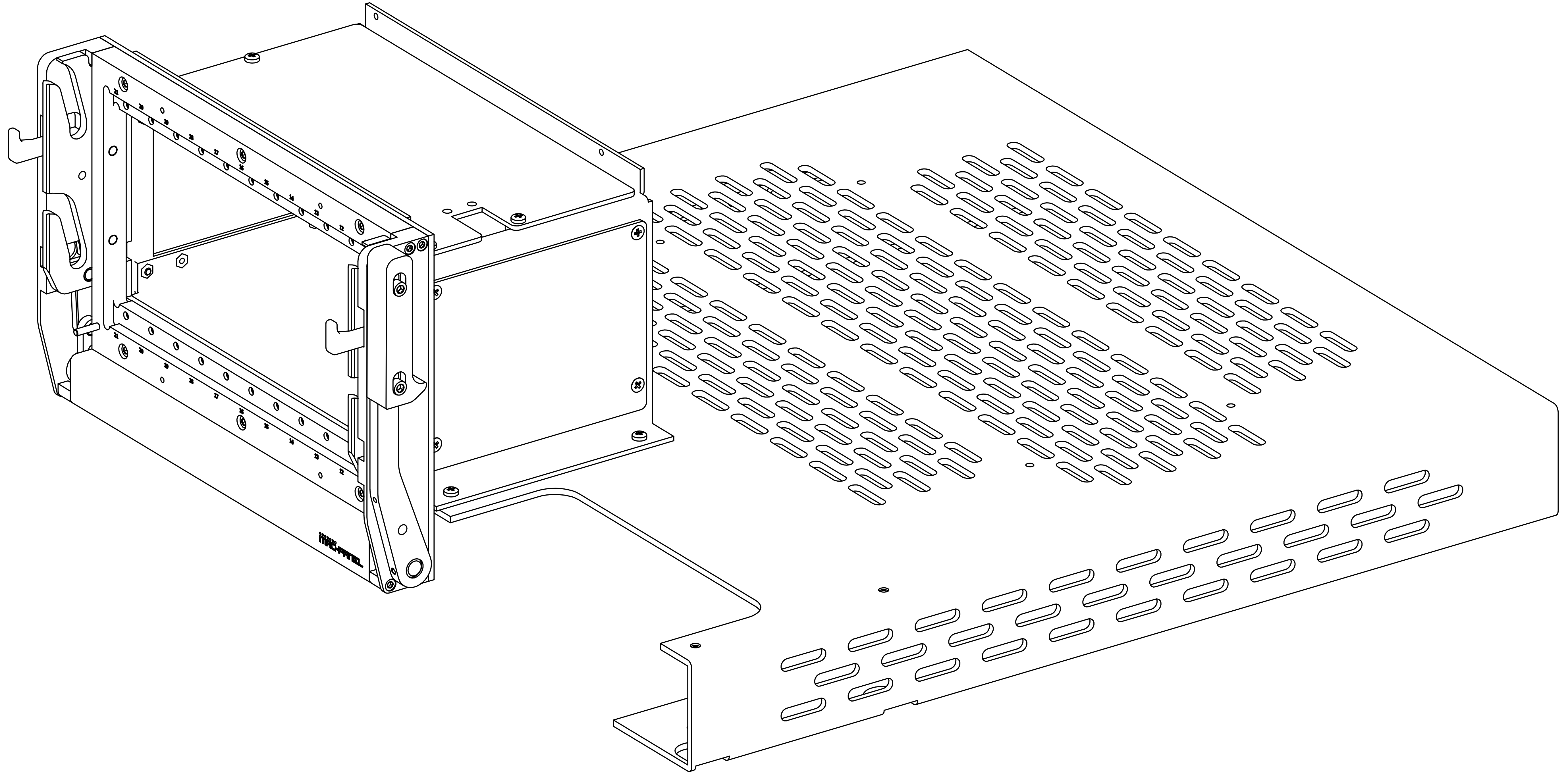

BALLOON LEGEND	
PART NUMBER	QTY

MAC PANEL PROPRIETARY
This document may contain confidential and proprietary information that is the property of MAC Panel Company that may not be disclosed to, or duplicated for others except as authorized by MAC Panel Company.

TOLERANCES (UNLESS OTHERWISE SPECIFIED)
SHEET METAL MACHINED
ANGLES ± 1° ANGLES ± 1°
.XX ± .03 .XX ± .01
.XXX ± .010 .XXX ± .005
.XXXX ± .0005 .XXXX ± .0005

REMOVE ALL BURRS AND BREAK SHARP EDGES.

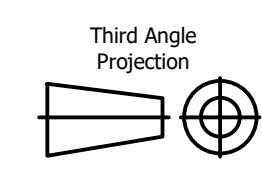

DRAWN BY STE	24/01/2017	MAC PANEL COMPANY - HIGH POINT, NC	
ENGINEERING		TITLE	
OPERATIONS		11 slot SCOUT Express with sheetmetal frame	
MANUFACTURING		SIZE	CAGE CODE DWG NO
ASSEMBLY		D	16654 561120-CU
MATERIAL USED		SCALE	SPN:
AS SHOWN			
			SHEET 3 OF 3

REV
B