

NOTES:

1. MODULE 1 PIN OUT PER 5518476WL REV A  
 MODULE 2 PIN OUT PER 5518475WL REV B.

2. BAG AND TAG P/NS 5510991 (2X), 5510941 (2X), AND 440E9230 (2X)  
 PRIOR TO SHIPPING.

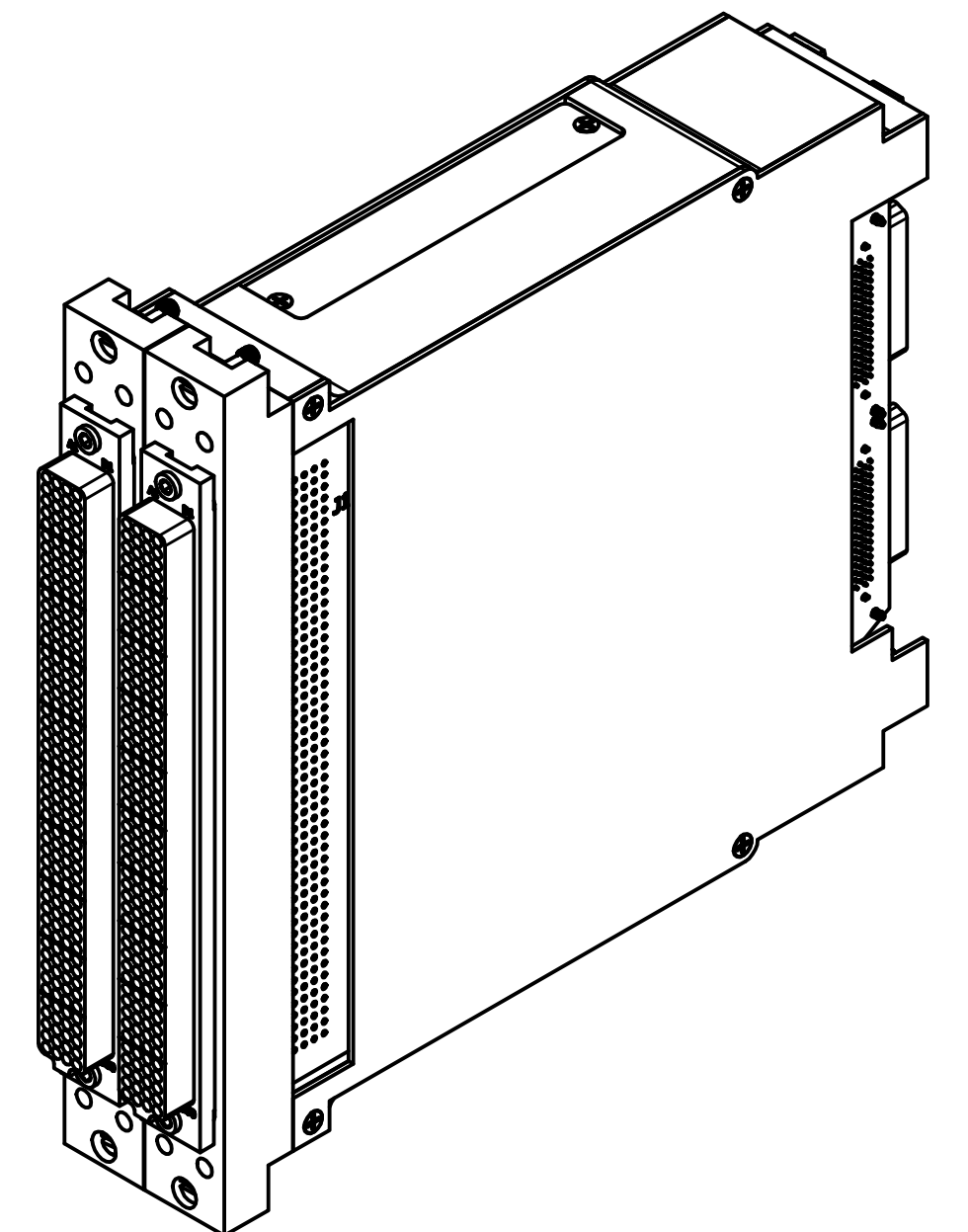
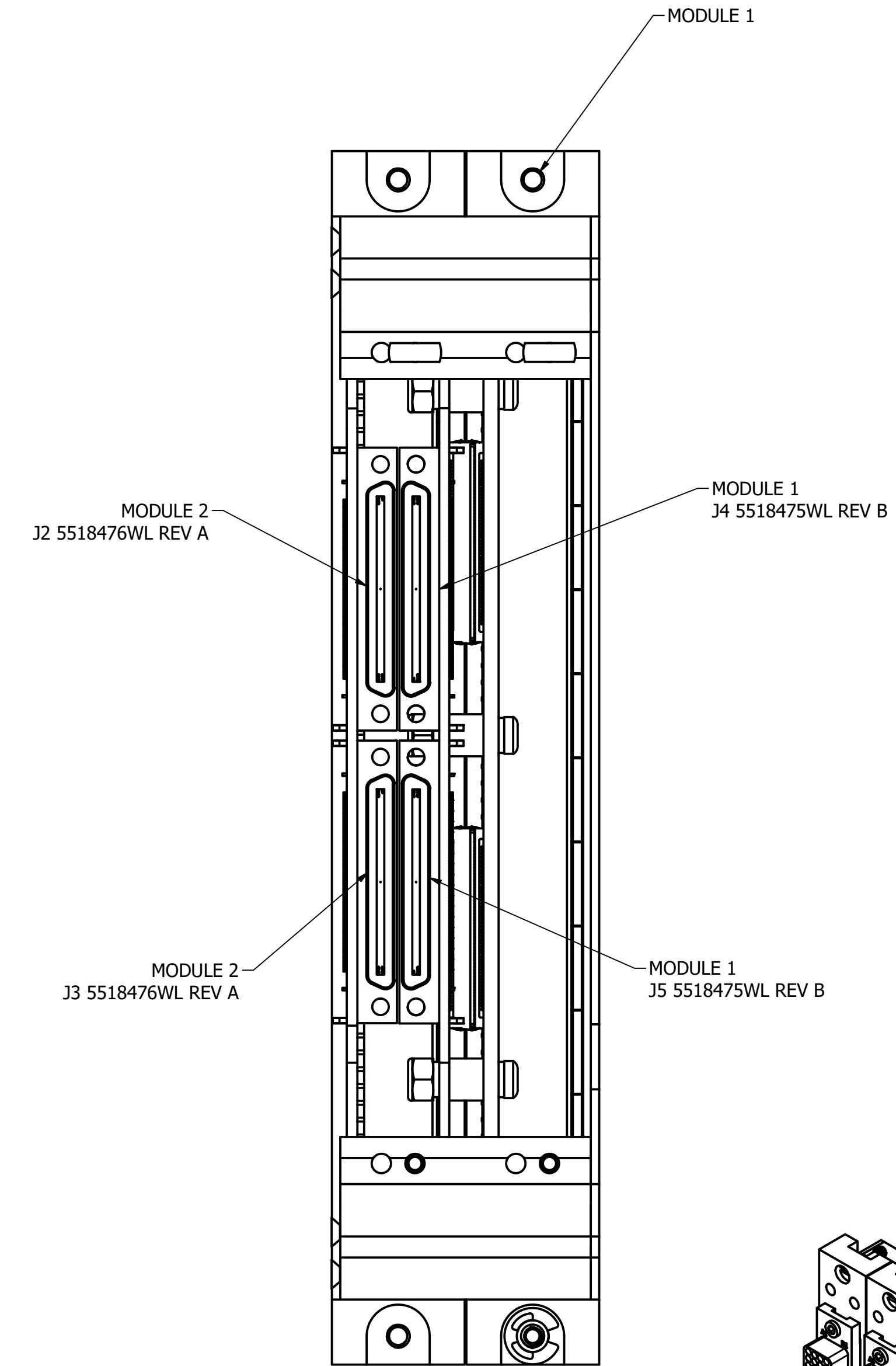
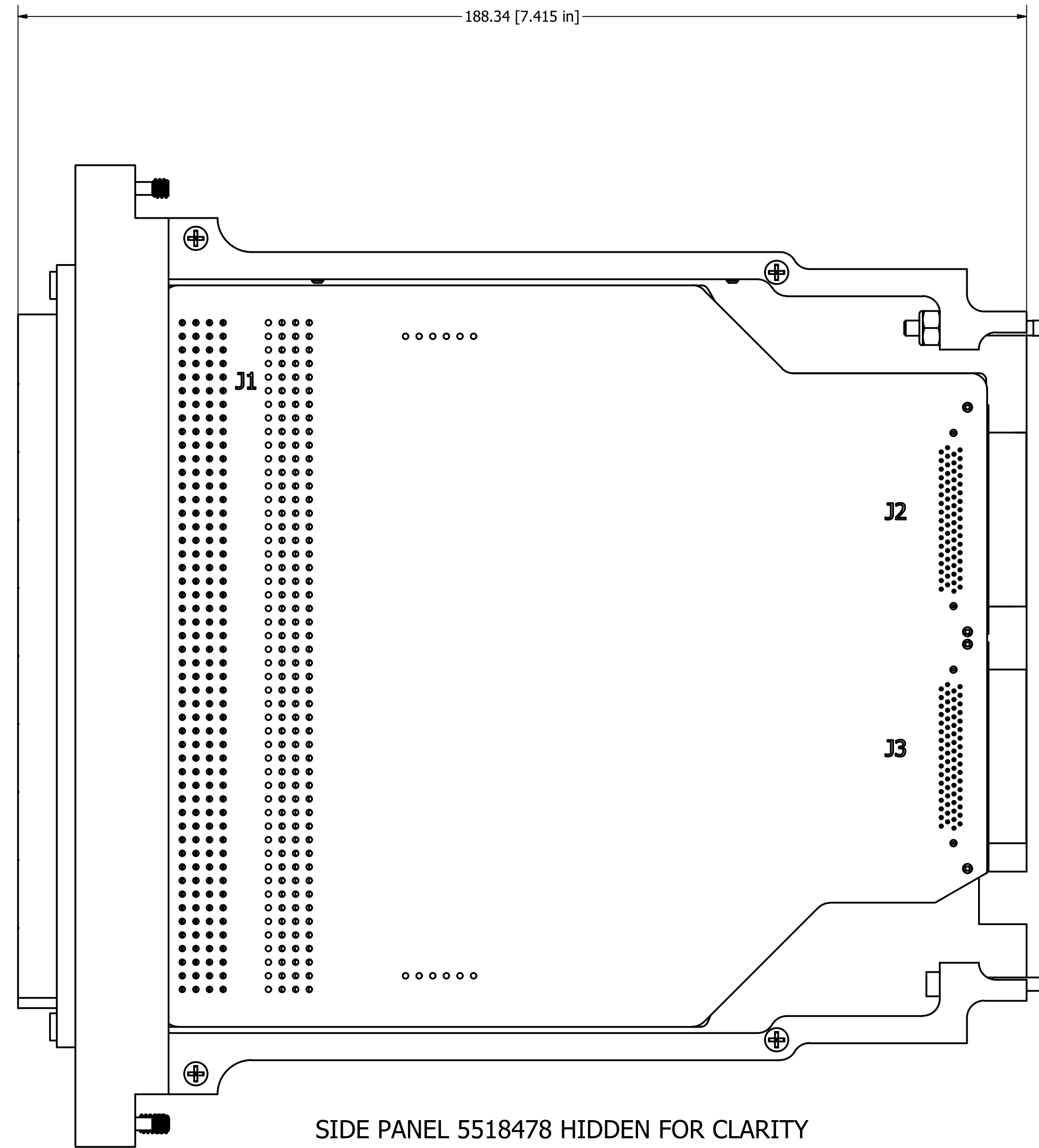
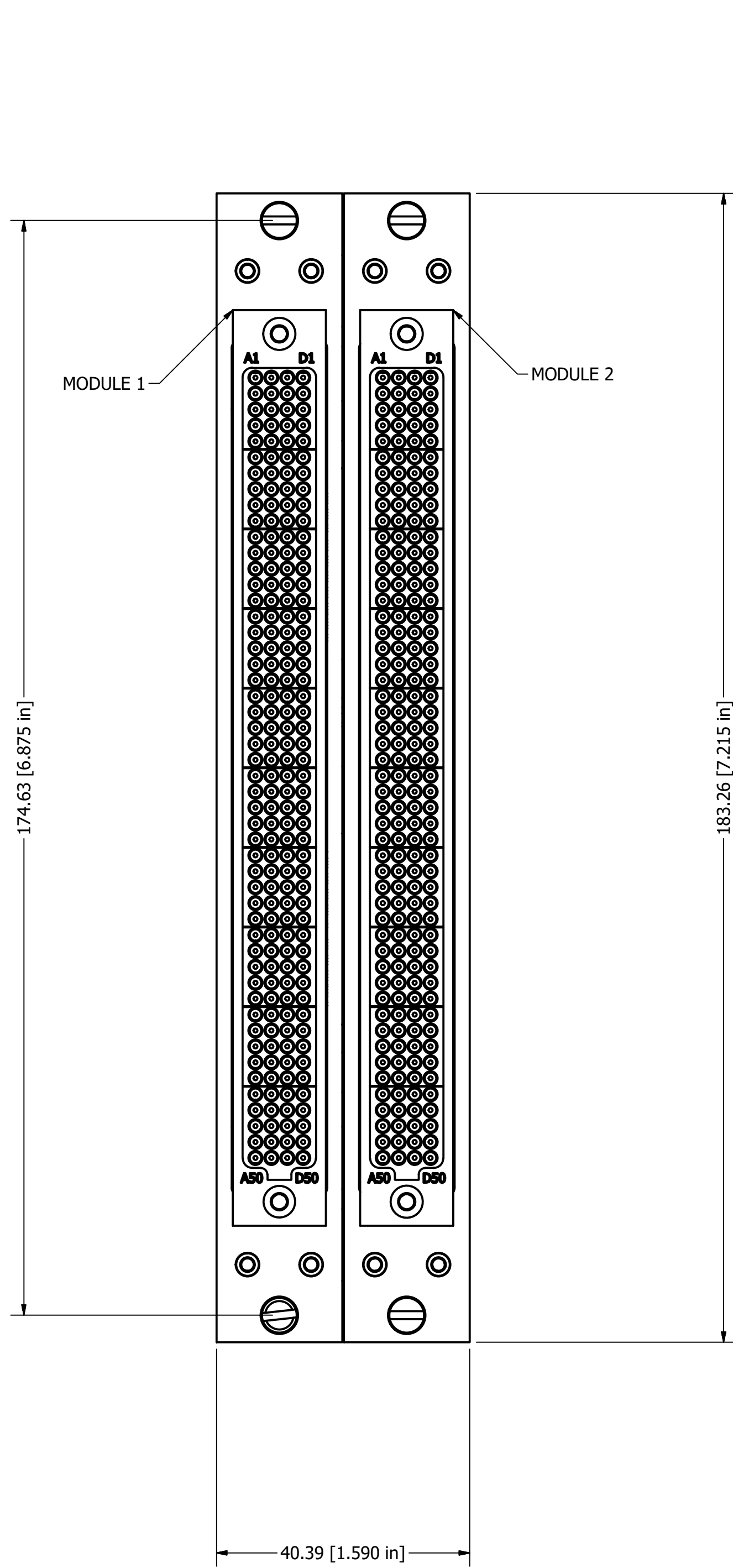

| BALLOON LEGEND |     |
|----------------|-----|
| PART NUMBER    | QTY |
|                |     |

MAC PANEL PROPRIETARY  
 This document may contain confidential and proprietary information that is the property of MAC Panel Company that may not be disclosed to, or duplicated for others except as authorized by MAC Panel Company.

TOLERANCES (UNLESS OTHERWISE SPECIFIED)

|             |               |
|-------------|---------------|
| SHEET METAL | MACHINED      |
| ANGLES ± 1° | ANGLES ± 1°   |
| .XX ± .03   | .XX ± .01     |
| .XXX ± .010 | .XXX ± .005   |
|             | .XXXX ± .0005 |

REMOVE ALL BURRS AND BREAK SHARP EDGES.

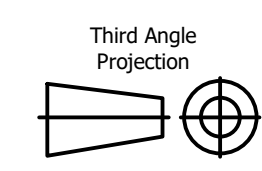

|                     |            |   |               |
|---------------------|------------|---|---------------|
| DRAWN BY<br>DCooper | 30/01/2019 | MAC PANEL COMPANY - HIGH POINT, NC              |               |
| ENGINEERING         |            | TITLE   |               |
| OPERATIONS          |            | DAK, PCB, 4x 68 pin VHDCI, 2slot, Extended, 1mm |               |
| MANUFACTURING       |            | SIZE  | CAGE CODE     |
| ASSEMBLY            |            | D   | 16654         |
| MATERIAL USED       |            | DWG NO  | REV           |
| AS SHOWN            |            | 563222X1-CU                                     | B             |
|                     |            | SCALE   | SPN: 562799X1 |
|                     |            |   | SHEET 1 OF 3  |

NOTES:

1. MODULE 1 PIN OUT PER 5518476WL REV A  
 MODULE 2 PIN OUT PER 5518475WL REV B.

2. BAG AND TAG P/NS 5510991 (2X), 5510941 (2X), AND 440E9230 (2X)  
 PRIOR TO SHIPPING.

5518476WL

REV A

| TO (J1) | FROM (J2) | TO (J1) | FROM (J2) | TO (J1) | FROM (J3) | TO (J1) | FROM (J3) |
|---------|-----------|---------|-----------|---------|-----------|---------|-----------|
| A1      | 1         | B1      | 35        | C1      | 1         | D1      | 35        |
| A2      | 2         | B2      | 36        | C2      | 2         | D2      | 36        |
| A3      | 3         | B3      | 37        | C3      | 3         | D3      | 37        |
| A4      | 4         | B4      | 38        | C4      | 4         | D4      | 38        |
| A5      | 5         | B5      | 39        | C5      | 5         | D5      | 39        |
| A6      | 6         | B6      | 40        | C6      | 6         | D6      | 40        |
| A7      | 7         | B7      | 41        | C7      | 7         | D7      | 41        |
| A8      | 8         | B8      | 42        | C8      | 8         | D8      | 42        |
| A9      | 9         | B9      | 43        | C9      | 9         | D9      | 43        |
| A10     | 10        | B10     | 44        | C10     | 10        | D10     | 44        |
| A11     | 11        | B11     | 45        | C11     | 11        | D11     | 45        |
| A12     | 12        | B12     | 46        | C12     | 12        | D12     | 46        |
| A13     | 13        | B13     | 47        | C13     | 13        | D13     | 47        |
| A14     | 14        | B14     | 48        | C14     | 14        | D14     | 48        |
| A15     | 15        | B15     | 49        | C15     | 15        | D15     | 49        |
| A16     | 16        | B16     | 50        | C16     | 16        | D16     | 50        |
| A17     | 17        | B17     | 51        | C17     | 17        | D17     | 51        |
| A18     | 18        | B18     | 52        | C18     | 18        | D18     | 52        |
| A19     | 19        | B19     | 53        | C19     | 19        | D19     | 53        |
| A20     | 20        | B20     | 54        | C20     | 20        | D20     | 54        |
| A21     | 21        | B21     | 55        | C21     | 21        | D21     | 55        |
| A22     | 22        | B22     | 56        | C22     | 22        | D22     | 56        |
| A23     | 23        | B23     | 57        | C23     | 23        | D23     | 57        |
| A24     | 24        | B24     | 58        | C24     | 24        | D24     | 58        |
| A25     | 25        | B25     | 59        | C25     | 25        | D25     | 59        |
| A26     | 26        | B26     | 60        | C26     | 26        | D26     | 60        |
| A27     | 27        | B27     | 61        | C27     | 27        | D27     | 61        |
| A28     | 28        | B28     | 62        | C28     | 28        | D28     | 62        |
| A29     | 29        | B29     | 63        | C29     | 29        | D29     | 63        |
| A30     | 30        | B30     | 64        | C30     | 30        | D30     | 64        |
| A31     | 31        | B31     | 65        | C31     | 31        | D31     | 65        |
| A32     | 32        | B32     | 66        | C32     | 32        | D32     | 66        |
| A33     | 33        | B33     | 67        | C33     | 33        | D33     | 67        |
| A34     | 34        | B34     | 68        | C34     | 34        | D34     | 68        |
| A35     | -         | B35     | -         | C35     | -         | D35     | -         |
| A36     | -         | B36     | -         | C36     | -         | D36     | -         |
| A37     | -         | B37     | -         | C37     | -         | D37     | -         |
| A38     | -         | B38     | -         | C38     | -         | D38     | -         |
| A39     | -         | B39     | -         | C39     | -         | D39     | -         |
| A40     | -         | B40     | -         | C40     | -         | D40     | -         |
| A41     | -         | B41     | -         | C41     | -         | D41     | -         |
| A42     | -         | B42     | -         | C42     | -         | D42     | -         |
| A43     | -         | B43     | -         | C43     | -         | D43     | -         |
| A44     | -         | B44     | -         | C44     | -         | D44     | -         |
| A45     | -         | B45     | -         | C45     | -         | D45     | -         |

BALLOON LEGEND

|             |
|-------------|
| PART NUMBER |
| QTY         |

MAC PANEL PROPRIETARY  
 This document may contain confidential and proprietary information that is the property of MAC Panel Company that may not be disclosed to, or duplicated for others except as authorized by MAC Panel Company.

TOLERANCES (UNLESS OTHERWISE SPECIFIED)

|                          |   |
|--------------------------|---|
| SHEET METAL              | MACHINED                                  |
| ANGLES ± 1°              | ANGLES ± 1°                               |
| .XX ± .03<br>.XXX ± .010 | .XX ± .01<br>.XXX ± .005<br>.XXXX ± .0005 |

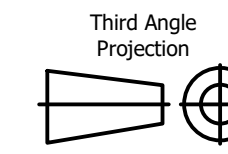

REMOVE ALL BURRS AND BREAK SHARP EDGES.

|                     |               |   |           |
|---------------------|---------------|---|-----------|
| DRAWN BY<br>DCooper | 30/01/2019    | MAC PANEL COMPANY - HIGH POINT, NC              |           |
| ENGINEERING         |               | TITLE   |           |
| OPERATIONS          |               | DAK, PCB, 4x 68 pin VHDCI, 2slot, Extended, 1mm |           |
| MANUFACTURING       |               | SIZE  | CAGE CODE |
| ASSEMBLY            |               | D   | 16654     |
| MATERIAL USED       |               | DWG NO  | REV       |
| AS SHOWN            |               | 563222X1-CU                                     | B         |
| SCALE               | SPN: 562799X1 | SHEET 2 OF 3                                    |           |

NOTES:

1. MODULE 1 PIN OUT PER 5518476WL REV A  
MODULE 2 PIN OUT PER 5518475WL REV B.

2. BAG AND TAG P/NS 5510991 (2X), 5510941 (2X), AND 440E9230 (2X)  
PRIOR TO SHIPPING.

| TO (J1) | FROM (J4) | TO (J1) | FROM (J4) | TO (J1) | FROM (J5) | TO (J1) | FROM (J5) |
|---------|-----------|---------|-----------|---------|-----------|---------|-----------|
| D1      | 68        | C1      | 67        | B1      | 68        | A1      | 67        |
| D2      | 66        | C2      | 65        | B2      | 66        | A2      | 65        |
| D3      | 64        | C3      | 63        | B3      | 64        | A3      | 63        |
| D4      | 62        | C4      | 61        | B4      | 62        | A4      | 61        |
| D5      | 60        | C5      | 59        | B5      | 60        | A5      | 59        |
| D6      | 58        | C6      | 57        | B6      | 58        | A6      | 57        |
| D7      | 56        | C7      | 55        | B7      | 56        | A7      | 55        |
| D8      | 54        | C8      | 53        | B8      | 54        | A8      | 53        |
| D9      | 52        | C9      | 51        | B9      | 52        | A9      | 51        |
| D10     | 50        | C10     | 49        | B10     | 50        | A10     | 49        |
| D11     | 48        | C11     | 47        | B11     | 48        | A11     | 47        |
| D12     | 46        | C12     | 45        | B12     | 46        | A12     | 45        |
| D13     | 44        | C13     | 43        | B13     | 44        | A13     | 43        |
| D14     | 42        | C14     | 41        | B14     | 42        | A14     | 41        |
| D15     | 40        | C15     | 39        | B15     | 40        | A15     | 39        |
| D16     | 38        | C16     | 37        | B16     | 38        | A16     | 37        |
| D17     | 36        | C17     | 35        | B17     | 36        | A17     | 35        |
| D18     | 34        | C18     | 33        | B18     | 34        | A18     | 33        |
| D19     | 32        | C19     | 31        | B19     | 32        | A19     | 31        |
| D20     | 30        | C20     | 29        | B20     | 30        | A20     | 29        |
| D21     | 28        | C21     | 27        | B21     | 28        | A21     | 27        |
| D22     | 26        | C22     | 25        | B22     | 26        | A22     | 25        |
| D23     | 24        | C23     | 23        | B23     | 24        | A23     | 23        |
| D24     | 22        | C24     | 21        | B24     | 22        | A24     | 21        |
| D25     | 20        | C25     | 19        | B25     | 20        | A25     | 19        |
| D26     | 18        | C26     | 17        | B26     | 18        | A26     | 17        |
| D27     | 16        | C27     | 15        | B27     | 16        | A27     | 15        |
| D28     | 14        | C28     | 13        | B28     | 14        | A28     | 13        |
| D29     | 12        | C29     | 11        | B29     | 12        | A29     | 11        |
| D30     | 10        | C30     | 9         | B30     | 10        | A30     | 9         |
| D31     | 8         | C31     | 7         | B31     | 8         | A31     | 7         |
| D32     | 6         | C32     | 5         | B32     | 6         | A32     | 5         |
| D33     | 4         | C33     | 3         | B33     | 4         | A33     | 3         |
| D34     | 2         | C34     | 1         | B34     | 2         | A34     | 1         |
| D35     | -         | C35     | -         | B35     | -         | A35     | -         |
| D36     | -         | C36     | -         | B36     | -         | A36     | -         |
| D37     | -         | C37     | -         | B37     | -         | A37     | -         |
| D38     | -         | C38     | -         | B38     | -         | A38     | -         |
| D39     | -         | C39     | -         | B39     | -         | A39     | -         |
| D40     | -         | C40     | -         | B40     | -         | A40     | -         |
| D41     | -         | C41     | -         | B41     | -         | A41     | -         |
| D42     | -         | C42     | -         | B42     | -         | A42     | -         |
| D43     | -         | C43     | -         | B43     | -         | A43     | -         |
| D44     | -         | C44     | -         | B44     | -         | A44     | -         |
| D45     | -         | C45     | -         | B45     | -         | A45     | -         |
| D46     | -         | C46     | -         | B46     | -         | A46     | -         |
| D47     | -         | C47     | -         | B47     | -         | A47     | -         |
| D48     | -         | C48     | -         | B48     | -         | A48     | -         |
| D49     | -         | C49     | -         | B49     | -         | A49     | -         |
| D50     | -         | C50     | -         | B50     | -         | A50     | -         |

**BALLOON LEGEND**

|             |
|-------------|
| PART NUMBER |
| QTY         |

MAC PANEL PROPRIETARY  
This document may contain confidential and proprietary information that is the property of MAC Panel Company that may not be disclosed to, or duplicated for others except as authorized by MAC Panel Company.

TOLERANCES (UNLESS OTHERWISE SPECIFIED)  
SHEET METAL MACHINED  
ANGLES ± 1° ANGLES ± 1°  
XX ± .03 XX ± .01  
XXX ± .010 XXX ± .005  
XXXX ± .005 XXXX ± .0005

REMOVE ALL BURRS AND BREAK SHARP EDGES.

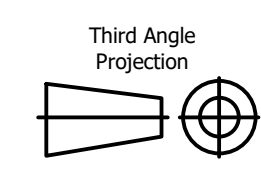

|                     |            |   |                   |
|---------------------|------------|---|-------------------|
| DRAWN BY<br>DCooper | 30/01/2019 | MAC PANEL COMPANY - HIGH POINT, NC              |                   |
| ENGINEERING         |            | TITLE   |                   |
| OPERATIONS          |            | DAK, PCB, 4x 68 pin VHDCI, 2slot, Extended, 1mm |                   |
| MANUFACTURING       |            | SIZE  | CAGE CODE DWG NO  |
| ASSEMBLY            |            | D   | 16654 563222X1-CU |
| MATERIAL USED       |            | SCALE   | SPN: 562799X1     |
| AS SHOWN            |            |   | SHEET 3 OF 3      |
|                     |            | REV   | B                 |