

8

7

6

5



4

3

2

1

NOTES:

1. SOLDER P/N 5512427 IN PLACE FIRST, THEN BEND TO DIMENSIONS SHOWN.

REVISION HISTORY			
REV	DESCRIPTION	DATE	APPROVED
B	NO ECN (REDRAWN IN INVENTOR SOFTWARE)	10/13/2008	WKM
C	ECN #2274 (REPLACED 0884030C-03 WITH 5512427)	11/17/2008	WKM

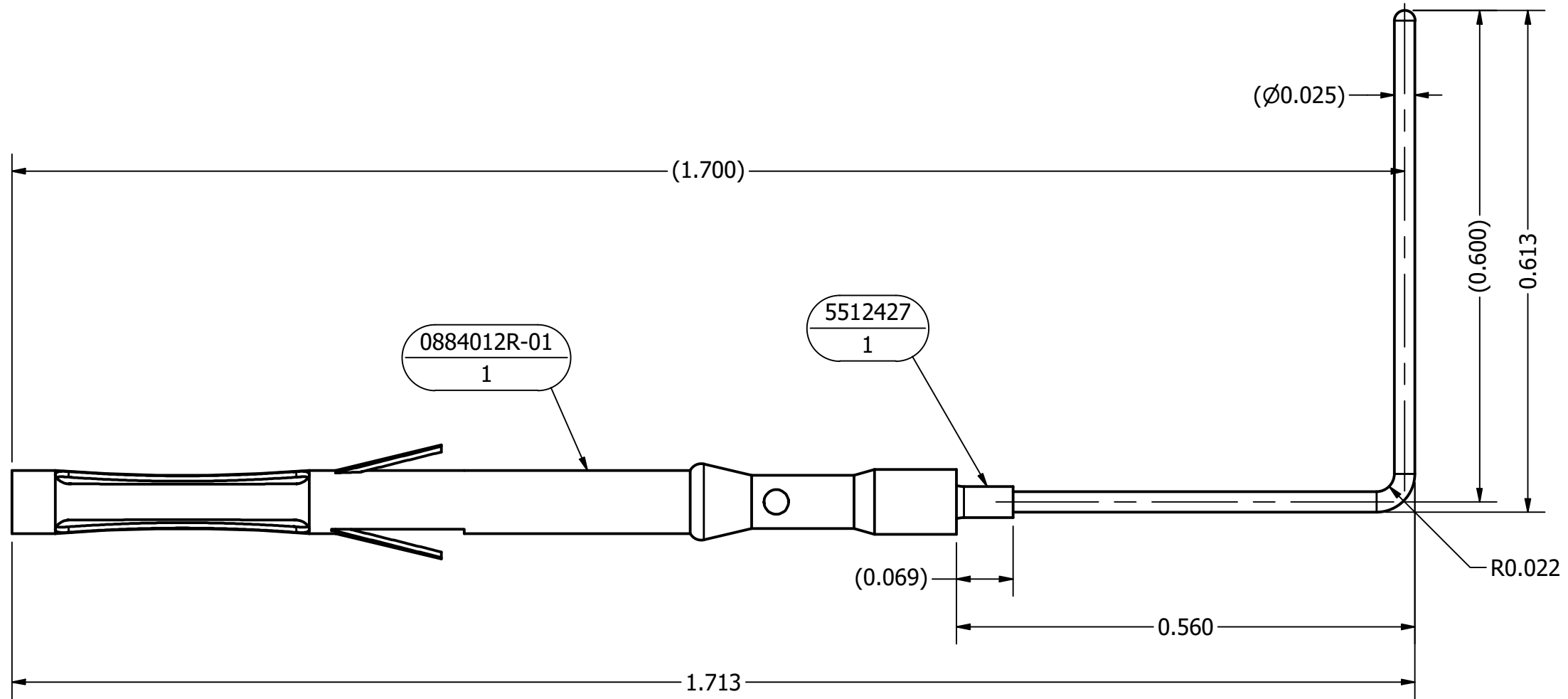

D

C



B

A

D

C



B

A

MAC PANEL PROPRIETARY  
 This document may contain confidential and proprietary information that is the property of MAC Panel Company that may not be disclosed to, or duplicated for others except as authorized by MAC Panel Company.

DRAWN BY  
 TRUNG  
 ENGINEERING  
 GAC  
 OPERATIONS

10/16/2002

MAC PANEL COMPANY - HIGH POINT, NC

BALLOON LEGEND	
PART NUMBER	QTY

TOLERANCES (UNLESS OTHERWISE SPECIFIED)

SHEET METAL	MACHINED
ANGLES ± 1'	ANGLES ± 1'
.XX ± .03	.XX ± .01
.XXX ± .010	.XXX ± .005
	.XXXX ± .0005

REMOVE ALL BURRS AND BREAK SHARP EDGES.

Third Angle Projection

MANUFACTURING  
 R.SPIVEY  
 ASSEMBLY

MATERIAL USED

TITLE		MAC PANEL COMPANY - HIGH POINT, NC	
SIGNAL CONTACT, RIGHT ANGLE, ROW 3			
SIZE	DWG NO		
B	0884029R-03		
SCALE	SPN: 0884029R-03	SHEET 1 OF 2	

8

7

6

5



4

3

2

1