

REVISION HISTORY			
REV	DESCRIPTION	DATE	APPROVED
A	RELEASE FOR PRODUCTION	11/6/2013	LCL
B	ECN#3613- ADDED WIRELIST TO DRAWING, CHANGED CALLOUT FOR SMB CONNECTIONS.	1/24/2014	LCL

MATING SIDE SHOWN

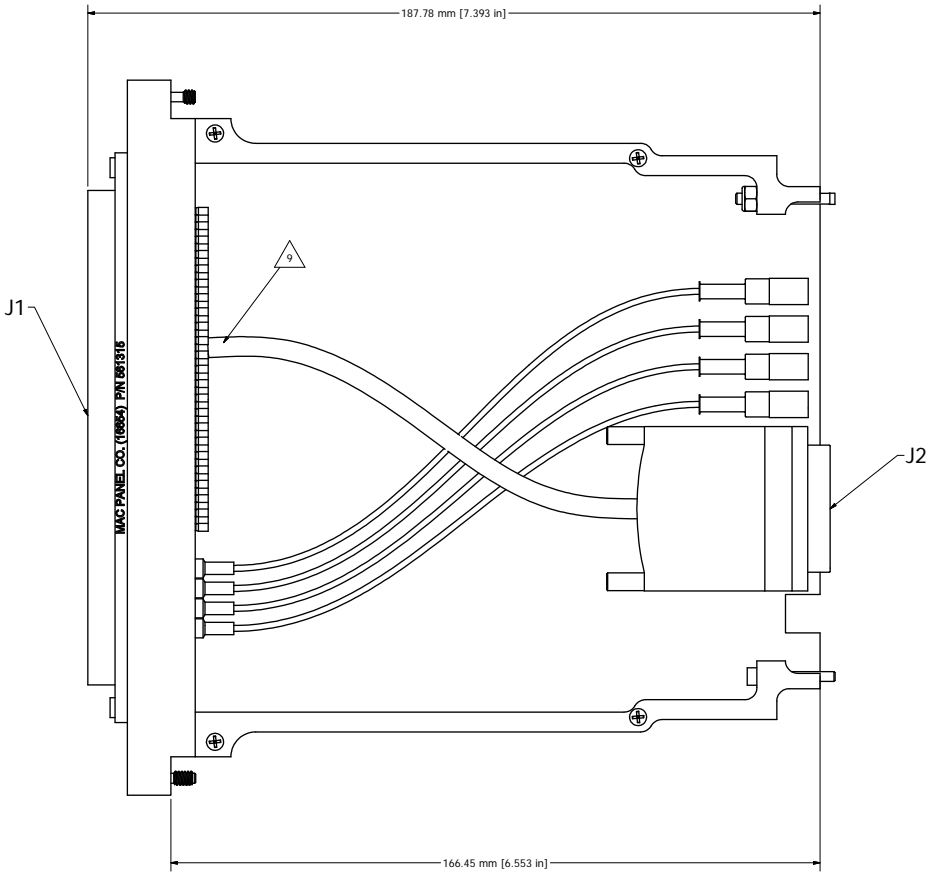

MATING SIDE SHOWN

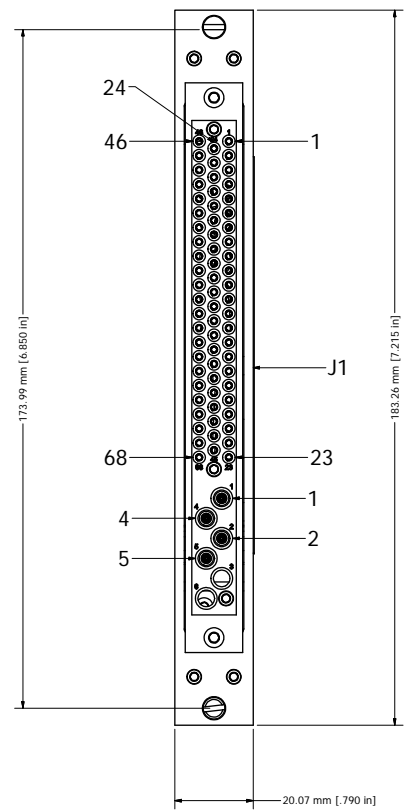
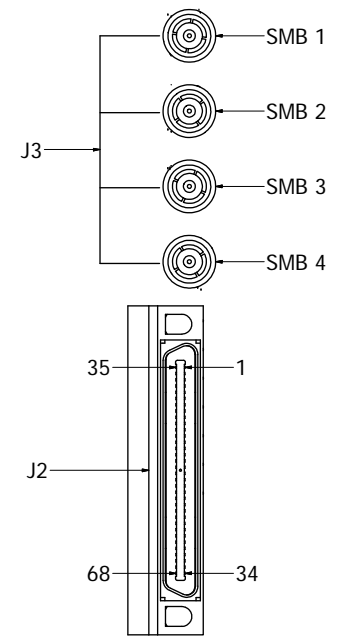

BALLOON LEGEND	
PART NUMBER	QTY

MAC PANEL PROPRIETARY
This document may contain confidential and proprietary information that is the property of MAC Panel Company that may not be disclosed to, or duplicated for others except as authorized by MAC Panel Company.

TOLERANCES (UNLESS OTHERWISE SPECIFIED)

ANGLES ± 1°	ANGLES ± 1°
XX ± .03	XX ± .01
XXX ± .010	XXX ± .005
	XXX ± .0005

REMOVE ALL BURRS AND BREAK SHARP EDGES.

Third Angle Projection

DRAWN BY	06/11/2013	MAC PANEL COMPANY - HIGH POINT, NC
ENGINEERING		TITLE
OPERATIONS		DAK, Cable, 68 pin VHDCI + 4 x SMB, Extended
MANUFACTURING		SIZE
ASSEMBLY		D
MATERIAL USED		CAGE CODE
		16654
		DWG NO
		561207X-cu
		REV
		B
		SCALE
		SPR
		SHEET 1 OF 2

MAC 561315	5210138 DIGITAL CBL	MAC 561315	5210138 DIGITAL CBL	MAC 561315	M1313403001 SMB
J1	J2	J1	J2	J1	J3
1	1	35	35	1	SMB 1
2	2	36	36	4	SMB 2
3	3	37	37	2	SMB 3
4	4	38	38	5	SMB 4
5	5	39	39		
6	6	40	40		
7	7	41	41		
8	8	42	42		
9	9	43	43		
10	10	44	44		
11	11	45	45		
12	12	46	46		
13	13	47	47		
14	14	48	48		
15	15	49	49		
16	16	50	50		
17	17	51	51		
18	18	52	52		
19	19	53	53		
20	20	54	54		
21	21	55	55		
22	22	56	56		
23	23	57	57		
24	24	58	58		
25	25	59	59		
26	26	60	60		
27	27	61	61		
28	28	62	62		
29	29	63	63		
30	30	64	64		
31	31	65	65		
32	32	66	66		
33	33	67	67		
34	34	68	68		
35	35	69	69		
36	36	70	70		
37	37	71	71		

MAC PANEL PROPRIETARY This document may contain confidential and proprietary information that is the property of MAC Panel Company that may not be disclosed to, or duplicated for others except as authorized by MAC Panel Company.		DRAWN BY ENGINEERING	06/11/2013	MAC PANEL COMPANY - HIGH POINT, NC
TOLERANCES (UNLESS OTHERWISE SPECIFIED): SHEET METAL: UNFINISHED: ANGLES ± .1" ANGLES ± .1"		TITLE DAK, Cable, 68 pin VHDCI + 4 x SMB, Extended		
XX ± .03 XY ± .01 XXX ± .010 XXX ± .005 XXXX ± .0005		MANUFACTURING ASSEMBLY		
REMOVE ALL BURRS AND BREAK SHARP EDGES.		MATERIAL USED SIZE CAGE CODE DWG NO D 16654 561207X-cu		
		SCALE SPN: SHEET 2 OF 2		

BALLOON LEGEND	
PART NUMBER	QTY